

METRIC SCREWS AND BOLTS

Table 7. American National Standard Metric Hex Flange Screws
ANSI/ASME B18.2.3.4M-1984

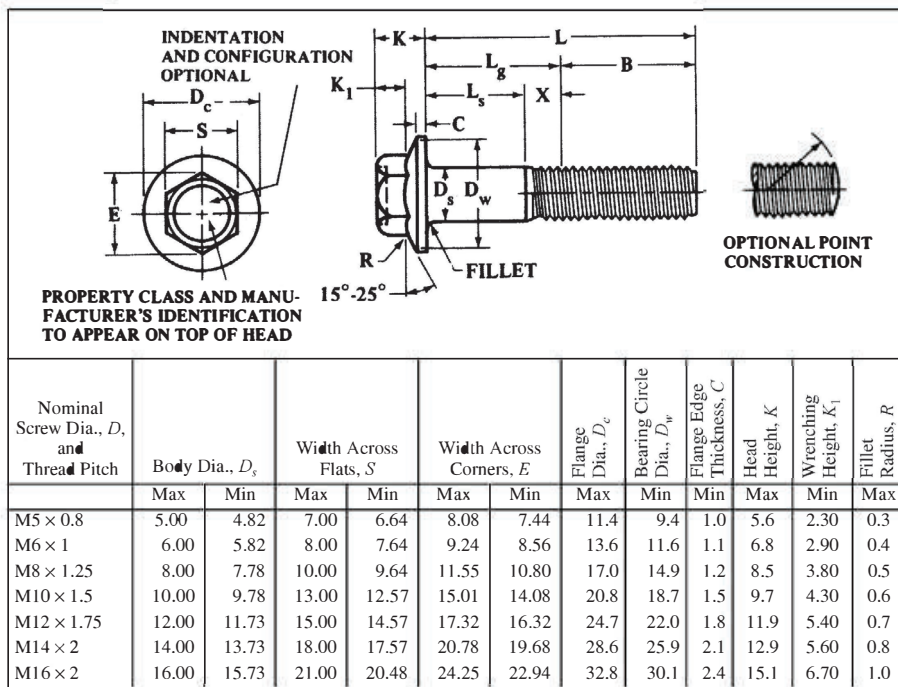

All dimensions are in millimeters. Basic thread lengths, B , are the same as given in Table 12. Transition thread length, x , includes the length of incomplete threads and tolerances on grip gaging length and body length. This dimension is intended for calculation purposes only. For additional manufacturing and acceptance specifications, reference should be made to ANSI/ASME B18.2.3.4M-1984 standard.